



# Instructions for the safe use of Flints Hanging Clamps

The information in this leaflet should be passed to  
the user of the equipment

This document is issued in accordance with the requirements of Section 6 of the Health and Safety at Work Act 1974, amended March 1988. These instructions apply to Flints Hanging Clamps with Codes FHS002HCS and FHS002LHCS

**Working Load Limit**  
**FHS002LHCS, FHS002HCS**  
**550kg\***

\*Reduce to 50 kg if shackles are used inverted

## Use for which the article is designed

Flints Hanging Clamps have been designed for the flying of conventional steel or aluminium flying bars in the indoor theatre environment. It is assumed the flying bars are flown using standard theatre counterweight or hemp systems or power flying systems fitted with soft starts. The fittings may also be used as an attachment point for suspending lines from trussing. The use of the fittings for any other purpose would be inappropriate. The fittings should be fitted to the tube by a competent person familiar with the theatre environment.

## Always

- ✓ Store the fittings in a area which is dry, clean and protected from corrosion.
- ✓ Inspect the fittings before putting into use and before being placed into storage. Any fittings found to be faulty should be marked as such and taken out of service and destroyed.
- ✓ Ensure fittings are selected and fitted by a competent person.
- ✓ Ensure the bolts are tightened to the correct torque settings.
- ✓ Ensure the fittings are used in such a way that the failure of any one fitting would not lead to a dangerous situation.
- ✓ Ensure any fitting subjected to excessive load by way of shock loading or any other means is immediately removed from service and marked for destruction.
- ✓ Follow the fitting instructions with particular regard to tube size and the distance between the matching halves.
- ✓ Ensure the load is applied in the direction as stated in the instructions.
- ✓ Ensure the fittings are thoroughly inspected by a competent person at six monthly intervals or after any exceptional circumstance or according to an examination scheme.
- ✓ Individually mark the fittings and record their details together with the EC Declaration of Conformity.

## Never

- ✗ Exceed the working load limit.
- ✗ Exceed the stated torque setting for the bolts.
- ✗ Subject fittings to shock loads.
- ✗ Never use a fitting which is bent, modified in an unapproved manner, stretched, has nicks, gouges or cracks, has signs of heat or burning, or signs of corrosion.
- ✗ Apply a load without ensuring any shackles or rigging screws are correctly aligned.

## Selection of Correct Fitting

Choose type FHS002HCS for barrel diameters of 48mm to 51mm. Choose FHS002LHCS for gas barrel 60.3mm diameter.

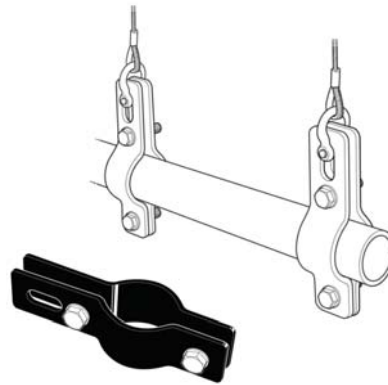

**Correct Fitting** Hanging Clamps should be attached to the tube using the Grade 8.8 hexagonal M10 bolts, washers and Nylon insert nuts provided. Some bolt thread should be visible after the Nylon insert nut has been tightened. The bolts must be clean and not lubricated and tightened to 3.5Nm assuming the radius of the fitting fits snugly around the radius of the bar. If the points of contact on the bar

are limited to the top and bottom of the bracket then the maximum torque should be limited to 1.75Nm. Please note that over tightening the bolts by means of impact drivers etc. could lead to the failure of the clamp. For instance a 50Nm tightening force leading to an applied force of 26kN equates to a 2000% utilisation of the clamp.

To obtain the stated Working Load Limit the distance between the plates should not exceed 10mm and the matching halves should be parallel. The top slot is 13.5mm wide and is designed to take the pin of a 1 t or 1.5 t US Fed Spec or equivalent shackle. To achieve the WLL of 550 kg the pin of the shackle must go through the slot. If the shackle is used inverted then the WLL should be reduced to 50 kg. A minimum of three lines should be used on a flying bar. Before flying out carefully inspect any tube joiners in use along the bar to ensure they are correctly fitted and preferably through bolted.

**Safe Use** The load should be applied vertically in line with the Hanging Clamps. Bridles may be employed but the angle subtended between the wire and the vertical should not exceed 45° and the bridle must be along the axis of the flying bar. Before applying a load ensure any shackles and rigging screws are correctly aligned. If the Hanging Clamp is not in a vertical plane when lifting objects then this reduces the WLL to 47kg. Care should be taken during flying to avoid shock loads which may arise due to wires becoming slack if a piece of scenery becomes caught on a fixed object while flying in.

**In Service Inspection and Maintenance** The fittings should be kept clean and free of corrosion. They must be inspected every six months or after any exceptional circumstance or according to an examination scheme drawn up by a competent person. Inspect for illegible markings, distortion, wear, stretched or bent clamps or rings, nicks, gouges, cracks, corrosion, heat marks or any other defect. If in doubt replace the fitting or seek further advice.

© Copyright Flint Hire & Supply Ltd. December 2012



FS 539611



flints.co.uk

**FLINTS**  
Theatrical Chandlers